

Datasheet

DCU150

Version 1.0

Revision History

Revision	Date	Change Description
1.0	Apr-2021	Preliminary version

Table of Contents

1. Introduction.....	4
1.1. Key Features	4
1.2. Applications	4
2. Electrical characteristics	5
2.1. Recommended operating conditions	5
2.2. RF characteristics.....	5
2.3. Antenna information	6
3. Module package.....	7
3.1. Pinout Description	7
3.2. Pin Description Box.....	8
3.3. Package outline	9
3.4. Recommended PCB Footprint	10
3.5. Host Board mounting	11
4. Soldering Condition	12
4.1. Manual Soldering – Pb Free	12
4.2. Recommended Reflow Condition – Pb Free.....	12
5. Application design-in information	13
5.1. Reference schematics for DCU150	13
6. Regulatory information	14

1. Introduction

Based on the NXP chip, DMC UWB module integrates the clock circuit, Antenna etc., which conforms to the IEEE 802.15.4z HRP UWB standard. PHY and MAC conform to the FiRa Consortium specification.

DCU150#A module is a switch-less 2D AoA solution without extra-antenna overhead, no phase/amplitude skew, no SPST insertion loss and low-cost design.

1.1. Key Features

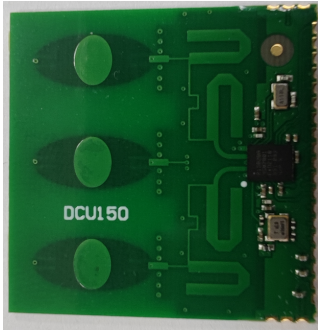
	
Name	DCU150#A
Antenna Type	Onboard
Size	27mm * 27.2mm * 1.5mm
Communication Interface	SPI
Main Chip	SR150
Channel	5, 6, 8, 9
Frequency range	6.24GHz~8.24GHz
Supply Voltage	1.71V ~ 1.98V
Max Output Power (EIRP)	14.1dBm @ CH9
Ranging Mode	2D Ranging

1.2. Applications

The perfect ANCHOR for High Precision RTLS (AoA), Industrial, Smart Home & Consumer applications. Smart Home Devices (Point & Trigger), Access Control (Physical and Logical) and Secure payments.

2. Electrical characteristics

2.1. Recommended operating conditions

When the input voltage of the module is lower than the rated operating voltage, the operation will be unstable. Input voltage higher than the maximum rating will cause permanent damage to the module. At the same time, working under the maximum rating for a long time also affects the stability of the module.

Parameter	Min	Type	Max	Unit	Conditions/Notes
Operating Temperature	-30		+85	°C	
Supply Voltage	1.71	1.8	1.98	V	
HIGH level input voltage (V_{IH})	1.26	1.8	2.3	V	
LOW level input voltage (V_{IL})	-0.6	-	0.54	V	
HIGH level output voltage (V_{OH})	1.4	-	1.8	V	
LOW level output voltage (V_{OL})	-	-	0.2	V	

2.2. RF characteristics

Parameter	Min	Type	Max	Unit	Conditions/Notes
Frequency range	6240		8240	MHz	Channel 5 and 9
Channel bandwidth		500		MHz	
Power level range		32		dB	
Power level step		0.25		dB	
Rx Sensitivity (±10ppm carrier Offset)	Channel 5		-91.9	dBm	64 preamble, 6.8Mbps data rate
	Channel 9		-90	dBm	64 preamble, 6.8Mbps data rate

2.3. Antenna information

Antenna Type	PCB Embedded
Antenna Polarization	Linear
Peak directivity	5.3dBi @CH5 5.8dBi @CH9
Radiation efficiency	
Frequency range	6.0 ~ 8.5GHz

3. Module package

3.1. Pinout Description

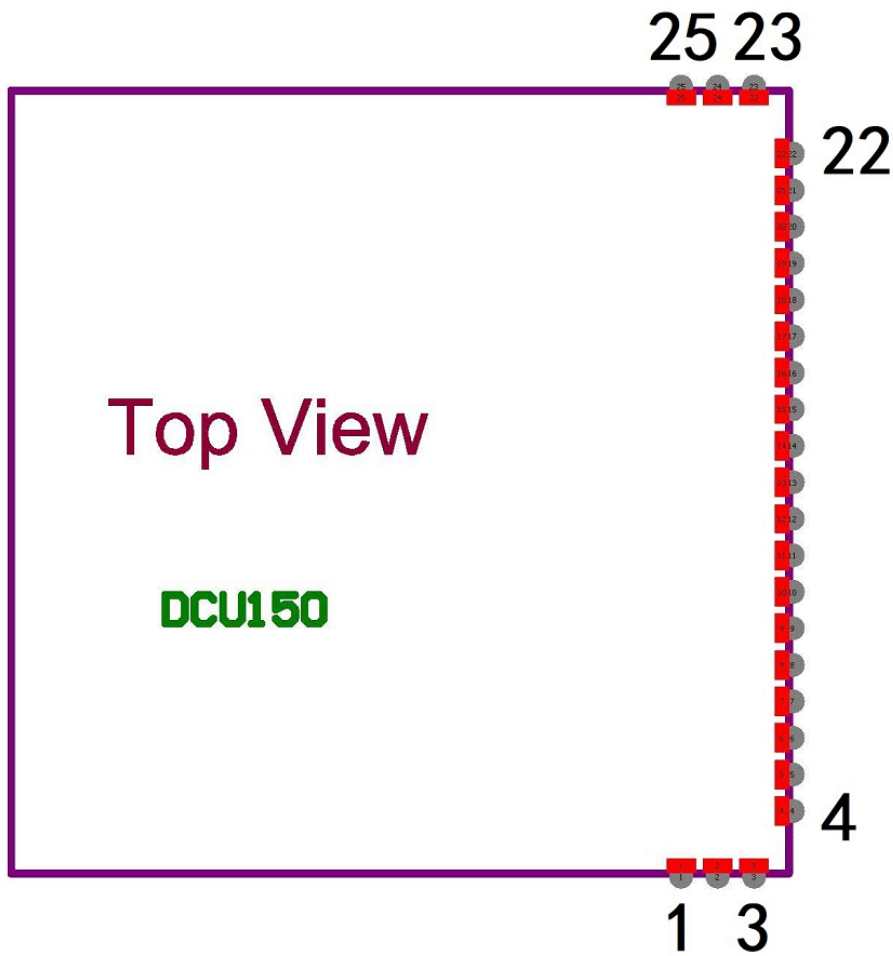

3.2.Pin Description Box

Pin	Pin Name	Pin Type	Description
1	COEX1	I/O	Default customer configuration as secondary I2C-bus clock line I2C_SCL, alternative configuration as secondary UART RX line, switching time is 125ns
2	GND	G	Ground
3	TV8_RF	P	Vin input for 1.8V RF and VDD supply for the Power Amplifier
4	GND	G	Ground
5	TV8_MCU	P	1.8V supply Input and Vin input to all Digital LDOs
6	TV8_DIG	P	Power Supply for the Host Interface and VDD supply for the IO pins
7	OSC_EN	I	Oscillator Enable
8	CHIP_EN	I	connection for disabling/enabling the chip
9	HOST_MISO	I/O	Host interface line 4, default configuration is SPI MISO connection alternating configuration I2C address 1, switching time is 125ns.
10	HOST_SCK	I	Host interface line 1, Default configuration is SPI clock line/ alternative configuration is clock for the I3C interface or clock for the I2C host interface, switching time is 125ns.
11	HOST_MOSI	I/O	Host interface line 3. Default configuration is SPI MOSI connection, alternative configuration is I2C address 0 or I3C address & data line "I3C_SDA", switching time is 125ns.
12	HOST_CS	I/O	Host interface line 2. Default configuration is SPI Slave select connection, alternating configuration is I2C SDA connection, switching time is 125ns.
13	GPIO_01	I/O	General Purpose IO, switching time is 125ns
14	GPIO_08	I/O	General Purpose IO, switching time is 125ns.
15	GPIO_02	I/O	General Purpose IO, switching time is 125ns.
16	SWD_IO	I/O	Serial Wire Debug interface input/output Default customer configuration is secondary SPI bus MISO connection, switching time is 125ns.
17	COEX2	I/O	Default customer configuration as secondary I2C-bus address and data line I2C_SDA, alternative configuration as secondary UART TX line, switching time is 125ns.
18	SE_I2C_SDA	I/O	Embedded Secure Element I2C-bus, I2C_SDA connection, switching time is 125ns.
19	SE_I2C_SCL	I/O	Embedded Secure Element I2C Clk interface, I2C_SCL, switching time is 125ns.
20	UART2_RX	I/O	RX connection of the UART interface, switching time is 125ns.
21	GPIO03_IRQ	I	General Purpose Input, switching time is 125ns.
22	GPIO_05_HOST_INT	I/O	General Purpose IO, switching time is 125ns.
23	UART2_TX	I/O	TX connection of the UART interface, switching time is 125ns.
24	SWD_CLK	I/O	Serial Wire Debug interface clock input Default customer configuration as secondary SPI bus clock interface connection SPI_SCK, switching time is 125ns.
25	GND	G	Ground

3.3.Package outline

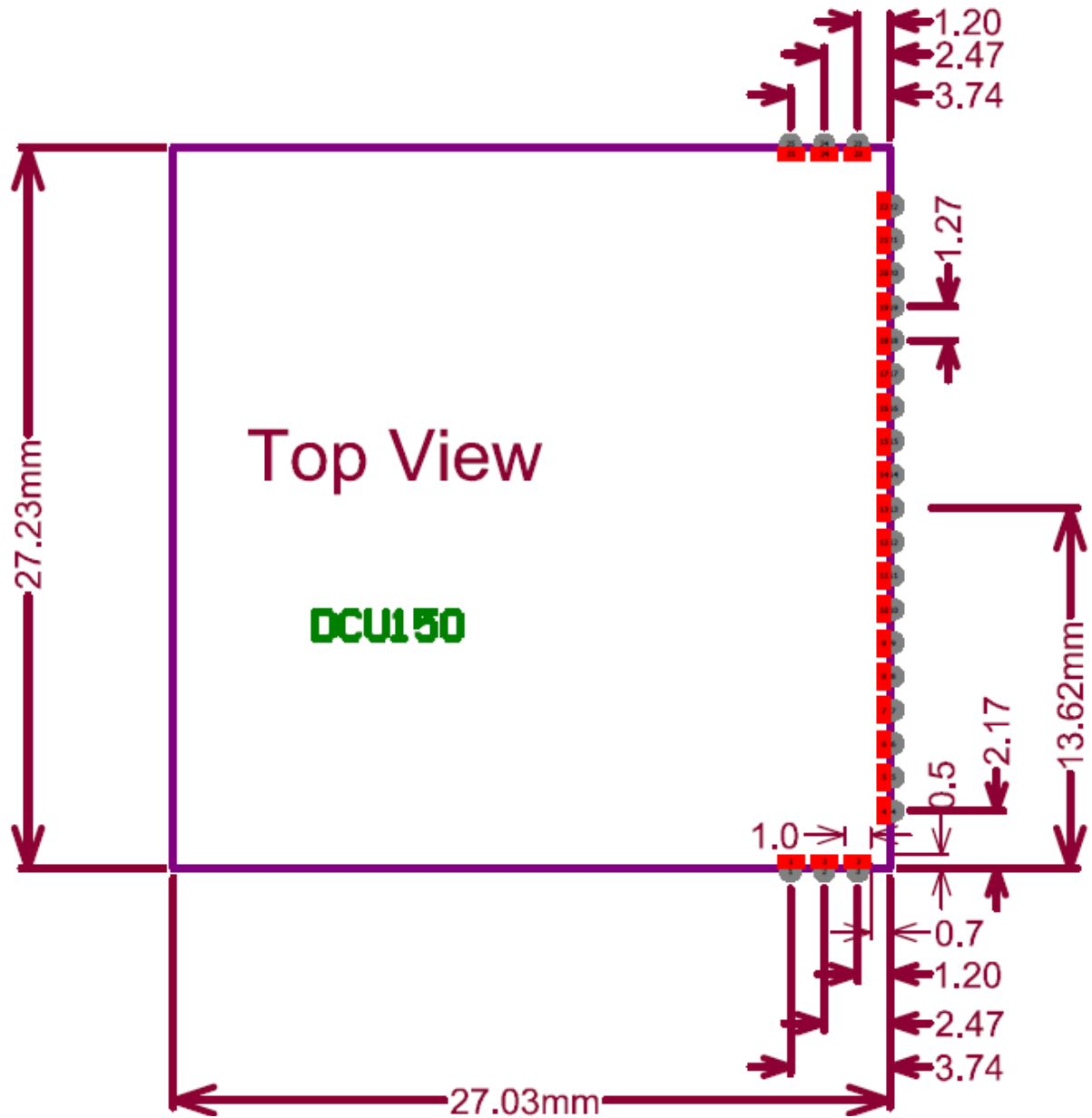

3.4. Recommended PCB Footprint

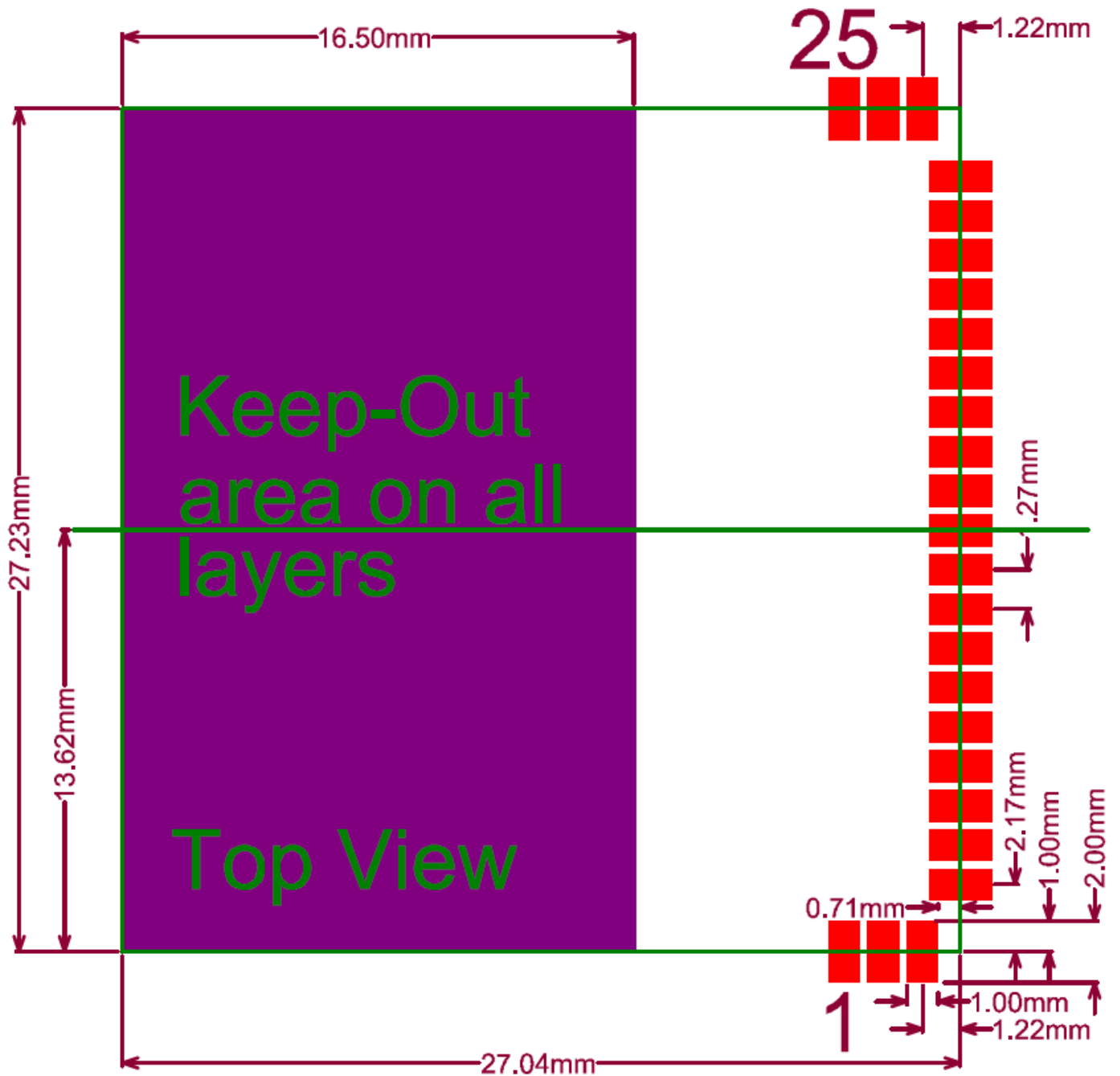

3.5 Host Board mounting

DCU150 is designed to be mounted onto a host board. Suggested host-board thickness is 0.8mm and it should be greater than 0.5mm. The DCU040 is preferably mounted close to the host board edge, as shown next. Maximum distance to the edge should be up to 1mm.

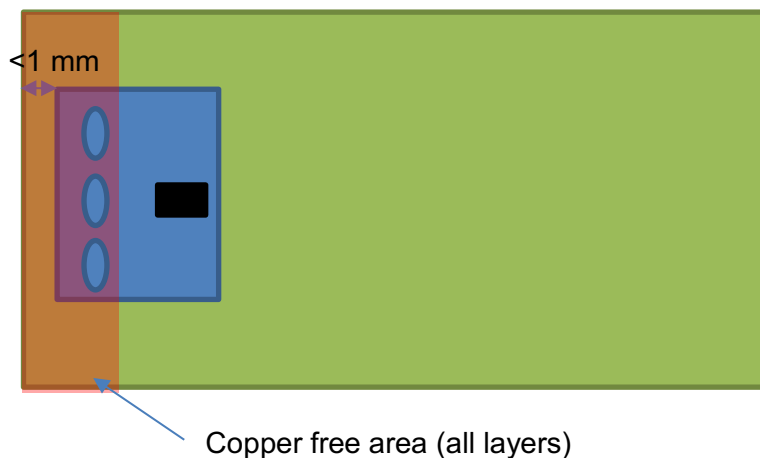

4. Soldering Condition

4.1. Manual Soldering – Pb Free

Soldering Temperature: 360°C ± 5°C, 5sec max.

4.2. Recommended Reflow Condition – Pb Free

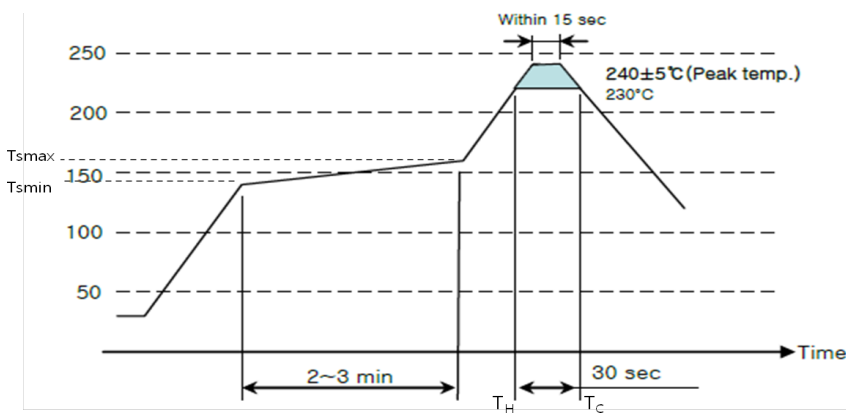

Profile Feature	Pb-Free Assembly
Preheat	
-Temperature Min (Tsmmin)	140°C
-Temperature Typical (Tstypical)	150°C
-Temperature Max (Tsmmax)	160°C
-Time Tsmmin to Tsmmax	2 ~ 3 min
Peak Temperature	240±5°C
Time of actual peak temperature	Max. 15 seconds
Heating to Cool	
-Temperature Heating (TH)	230°C
-Temperature Cool (TC)	230°C
-Time TH to TC	30 seconds

5. Application design-in information

5.1. Reference schematics for DCU150

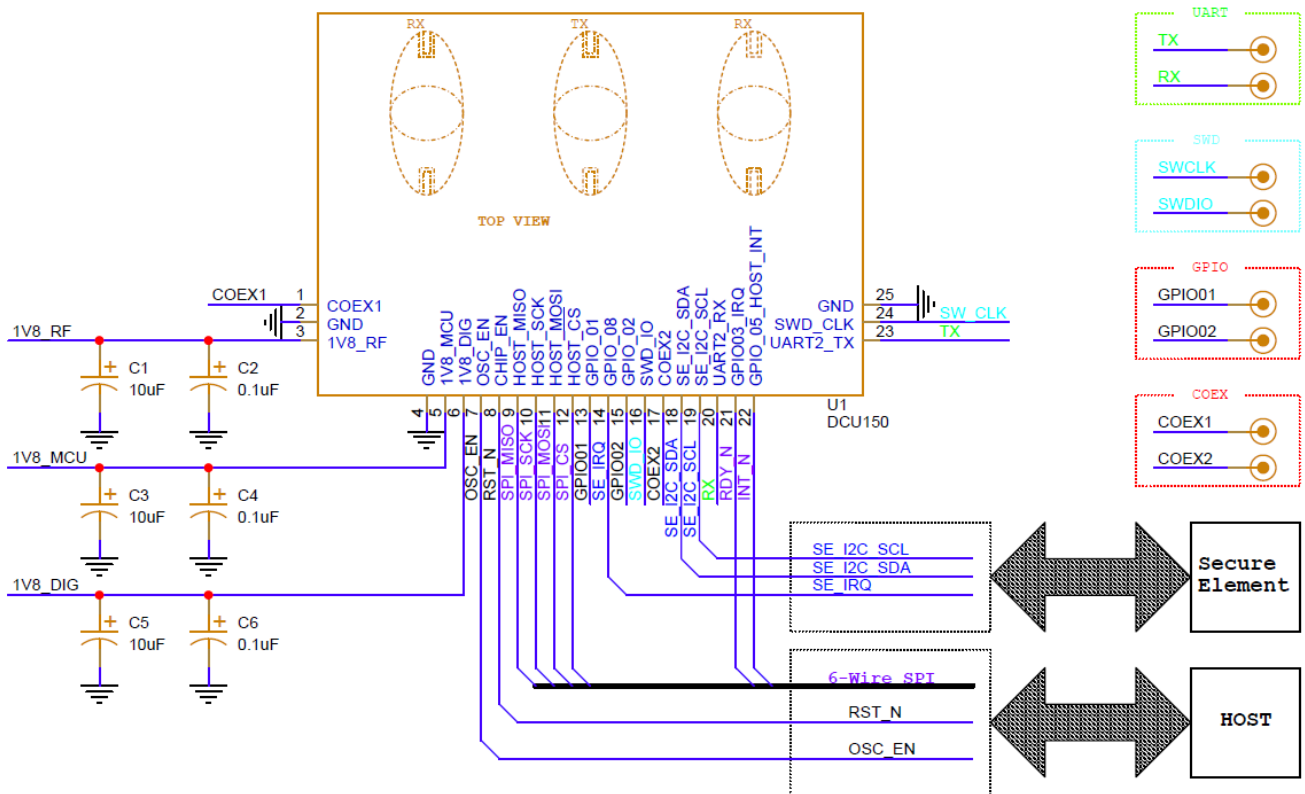

6. Regulatory information

Regulatory approvals are pending.